

Remote Controlling Of a Vehicle Using Android App. Using 8051 Microcontroller

Aarzo Malik, Apoorv Shrivastava, Gaurav Kumar Singh, Aparna Shukla

B.Tech Student

Department of Electronics & Communication Engineering

SRM University NCR Campus

Ghaziabad, India

ABSTRACT:

A robot is usually an electro-mechanical machine that is guided by computer and electronic programming. Many robots have been built for manufacturing purpose and can be found in factories around the world. Designing of the latest inverted ROBOT which can be controlling using an APP for android mobile. We are developing the remote buttons in the android app by which we can control the robot motion with them. And in which we use Bluetooth communication to interface controller and android. Controller can be interfaced to the Bluetooth module though UART protocol. According to commands received from android the robot motion can be controlled. The consistent output of a robotic system along with quality and repeatability are unmatched. Pick and Place robots can be reprogrammable and tooling can be interchanged to provide for multiple applications.

Keywords: Android Smartphone, Bluetooth module, robot, single microcontroller chip

1. INTRODUCTION

Nowadays smart phones are becoming more powerful with reinforced processors, larger storage capacities, richer entertainment function and more communication methods. Bluetooth is mainly used for data exchange; add new features to smart phones. Bluetooth technology, created by telecom vendor Ericsson in 1994[1], shows its advantage by integrating with smart phones. It has changed how people use digital device at home or office, and has transferred traditional wired digital devices into wireless devices. A host Bluetooth device is capable of communicating with up to seven Bluetooth modules at same time through one link [2]. Considering its normal working area of within eight meters, it is especially useful in home environment. Thank for Bluetooth technology and other similar techniques, with dramatic increase in Smartphone users, smart phones have gradually turned into an all-purpose portable device and provided people for their daily use [3]. In recent years, an open-source platform Android has been widely used in smart phones . Android has complete software package consisting of an operating system, middleware layer and core applications. Different from other existing platform like iOS (iPhone OS), it comes with software development kit (SDK), which provides essential tools and Application. Using a Smartphone as the “brain” of a robot is already an active research field with several open opportunities and promising possibilities. In this paper we present a review of current robots controlled by mobile phone and discuss a closed loop control systems using audio channels of mobile devices, such as phones and tablet computers. In our work, move the robot upward, backward, left and right side by the android application such as Arduino Bluetooth RC Car. This article is organized as follow: Section 2 describes the motivation of the work, Section 3 describes our experimental setup, Section 4 depicts a discussion about our experimental setup and Section 5 presents our conclusions.

2. PURPOSE

The purpose of our research is to provide simpler robot's hardware architecture but with powerful computational platforms so that robot's designer can focus on their research and tests instead of Bluetooth connection infrastructure. This simple architecture is also useful for educational robotics, because students can build their own robots with low cost and use them as platform for experiments in several courses.

Common control architectures: The following list shows typical robot control architecture:

2.1. AT89S52

The AT89S52 is a low-power, high performance CMOS 8-bit microcontroller with 8k bytes of in-system programmable flash memory. The device is manufactured using Atmel's high-density nonvolatile memory technology and is compatible with the industry-standard 80C51 instruction set and pin out. The Atmel AT89S52 is a powerful microcontroller which provides a highly-flexible and cost-effective solution to many embedded control applications.

The AT89S52 Provides the following standard features: 8K bytes of flash, 256 bytes of RAM, 32 I/O lines, Watchdog timer, two data pointers, three 16-bit timer/counters, a six-vector two-level interrupt architecture, a full duplex serial port, on-chip oscillator, and clock circuitry. The AT89S52 is designed with static logic for operation down to zero frequency and supports two software selectable power saving modes. The power-down mode saves the RAM contents but freezes the oscillator, disabling all other chip function until the next interrupt or hardware reset.

2.2. HC Serial Bluetooth

HC Serial Bluetooth product consists of Bluetooth serial interface module and Bluetooth adapter. Bluetooth serial module is used for converting serial port to Bluetooth. This module has two modes: master and slaver device. The device named after even number is defined to be master or slaver when out of factory and can't be changed to the other mode. But for the device named after odd number, users can set the work mode (master or slaver) of the device by AT commands.

HC-06 Specifically includes: Master device: HC-06-M, M=Master Slaver device: HC-06-S, S=Slaver

The main function of Bluetooth serial module is replacing the serial port line, such as:

One connects to Bluetooth master device while the other one connects to slaver device. Their connection can be built once the pair is made. This Bluetooth connection is equivalently linked to a serial port line connection including RXD, TXD signals. And they can communicate with each other.

1. When MCU has Bluetooth slave module, it can communicate with Bluetooth adapter of computer and smart phones.
2. The Bluetooth devices in the market mostly are slave devices, such as Bluetooth printer, Bluetooth GPS. So, we can use master module to make pair and communicate with them.
3. Bluetooth serial module's operation doesn't need driver, and can communicate with the other Bluetooth device. But communication between two Bluetooth modules requires two conditions:
 - i) The communication must be between master and slave.
 - ii) The password must be correct.

Here are the main factory parameters of HC-05 and HC-06. Pay attention to the difference:

Table 1.1

2.3. L293D

The L293 and L293D are quadruple high-current half-H drivers. The L293 is designed to provide bidirectional drive currents of up to 1A at voltage from 4.5V to 36V. The L293D is designed to provide bidirectional drive

currents of up to 600-MA at voltages from 4.5V to 36V. Both devices are designed to drive inductive loads such as relays, solenoids, dc and bipolar stepping motors, as well as other high-current/high voltage loads in positive-supply applications.

On the L293D, external high-speed output clamp diodes should be used for inductive transient suppression. A Vcc1 terminal, separate from Vcc2, is provided for the logic inputs to minimize device power dissipation. The L293 and L293D are characterized for operation from 0°C to 70°C.

2.4 DC MOTOR

Almost every mechanical movement that we see around us is accomplished by an electric motor. Electric machines are means of converting energy. Motors take electrical energy and produce mechanical energy. Electric motor is used to power hundreds of devices we use in everyday life. An example of small motor applications includes motors used in automobiles, robot, hand power tools and food blenders. Micro-machines are electric machines with parts the size of red blood cells and find many applications in medicine.

2.5 UART

Universal asynchronous receiver/ transmitter is usually an individual integrated circuit used for serial communications over a computer or peripheral device serial port. UART are now commonly included in microcontrollers. A dual UART combines two UARTS into a single chip. Many modern ICs come with a UART that can also communicate synchronously; these devices are called UART.

3. BLOCK DIAGRAM

A smart phone Android operated robot. Now here is a simple to control your robot/robo car using Bluetooth module HC-06 and 89c2051 microcontroller with your android Smartphone device. The controlling devices of the whole system are a microcontroller. Bluetooth module, DC motors are interfaced to the microcontroller. The data receive by the Bluetooth module from android smart phone is fed as input to the controller. The controller acts accordingly on the DC motor of the robot. The robot in the project can be made to move in all the four directions using the android phone. The direction of the robot is indicators using LED indicators of the Robot system. In achieving the task the controller is loaded with program written using Embedded 'C' Languages. Android smart phone controller Bluetooth robot using microcontroller is shown in figure 1.1.

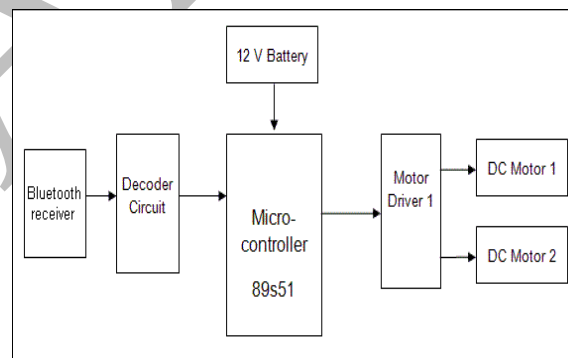

Figure 1.1: Block diagram of android smart phone controller Bluetoothrobot using 89s51 microcontroller

4. Application Instructions



Figure 1.2: Android Application Controlling Vehicle.

1. First make sure your HC-05 Bluetooth Module is paired with your mobile. The default password for pairing is "1234" or "0000". Check the manual of Bluetooth module.
2. Click on "SELECT DEVICE" icon to select paired Bluetooth module.
3. When you press "UP Arrow" it sends the data "A" to Bluetooth Module connected with the circuit. When Microcontroller detects "A" the Robot / Robot Car moves FORWARD.
4. When you press "Down Arrow" it sends the data "B" to Bluetooth Module connected with the circuit. When Microcontroller detects "B" the Robot / Robot Car moves REVERSE.
5. When you press "LEFT Arrow" it sends the data "C" to Bluetooth Module connected with the circuit. When Microcontroller detects "C" the Robot / Robot Car turns LEFT.
6. When you press "RIGHT Arrow" it sends the data "D" to Bluetooth Module connected with the circuit. When Microcontroller detects "D" the Robot / Robot Car turns RIGHT.
7. When you press "STOP" button which is in the center of remote it sends the data "E" to Bluetooth Module connected with the circuit. When Microcontroller detects "E" the Robot / Robot Car gets STOPPED.
8. When you press "360 Degree" button it sends the data "F" to Bluetooth Module connected with the circuit. When Microcontroller detects "F" the Robot / Robot Car rotates CLOCKWISE on the same position.
9. When you press "-360 Degree" button it sends the data "G" to Bluetooth Module connected with the circuit. When Microcontroller detects "G" the Robot / Robot Car rotates ANTI-CLOCKWISE on the same position.
10. Click on "DISCONNECT" icon to disconnect paired Bluetooth module.



Figure 1.3: Android phone Bluetooth controller ROBOT/ROBO

5. CONCLUSION

The objective of the paper is to realize the smart living, more specifically the home lighting control system using Bluetooth Technology. Robot and smart phones are a perfect match, especially mobile robots. As phones and mobile devices is each time more powerful, using them as robot for building robot with advanced feature such as voice recognition. Android Bluetooth-enable phones and Bluetooth module via HC-06 and communication among Bluetooth devices. It is concluded that smart living will gradually turn into areality that consumer can control their home remotely and wirelessly.

6. FUTURE WORK

The knowledge is ever expanding and so are the problems which the mankind strive to solve. In this spirit, it is hoped that the current activity will lead to further enhancements. For example; work on future for military purpose by the robot.

REFERENCE

1. Heidi Monson (1999) bluetooth technology and implementations, John Wiley & Sons.
2. Piyare, R. and Tazil, M. (2011) “ bluetooth based home automation system using Android phones”. IEEE 15TH International symposium on consumer electronics (ISCE), 14-17 june 2011, Singapure.
3. Potts, J. and Sukittanon, S. (2012) “ Explotingbluetooth on android mobile mobile devices for home security application”, proceedings of southeastcan, 15-18 March 2012, orlando, florida,USA.